

---

# User manual

---



# PYROS 3



**EN** Read this manual carefully, before the first use

---

**Product références :**

---

V90.00.041	PYROS 3 with remote control and wireless remote control
------------	---

# Contents

1	INTRODUCTION .....	4
2	SAFETY INSTRUCTIONS.....	6
3	GENERAL CHARACTERISTICS & PERFORMANCES .....	7
3.1	General characteristics	7
3.2	Charger characteristics	8
3.3	Gas supply	8
3.4	The remotes control	8
3.5	Wired remote control	8
3.6	Wireless remote control	8
4	IMPLEMENTATION INSTRUCTIONS.....	9
4.1	Assembly of the gas cylinder holder assembly	9
4.2	Connections and implementation	9
4.3	Gas cylinder connection	10
4.4	Positioning of the tray to the ground	10
4.5	Gas supply hose connection	10
4.6	Remote control connection	11
4.7	Filling the tray	11
5	USE OF PYROS 3.....	12
5.1	Arming	12
5.2	Use of extinguishing agents	13
5.3	Instructions for use	13
5.4	Stop PYROS 3	14
6	AUTONOMY AND POWER.....	15
7	SERVICING OPERATIONS .....	16
7.1	Precautions	16
7.2	Cleaning	16
7.3	Charging the battery	16
8	ACCESSORIES USE (OPTIONS) :.....	17
8.1	Adapter and accessories	17
8.2	Implementation of the adapter and accessories	18
8.3	Handling Training accessories	19
9	FAILURES.....	19
10	WARRANTY .....	20

# 1 INTRODUCTION

**PYROS 3** is a fire trainer with water tray. It allows training in the use of different extinguishing materials (all fire extinguishers, nozzles, portable foam units, etc ...) safely and with respect for the environment.

Thanks to its wired remote control or its wireless remote control, **PYROS 3** allows the trainer to manage the fire (switching on and off) to accompany trainees safely during training interventions.

The trainings conducted with **PYROS 3** can be supplemented with the use of training modules and enable personalized and realistic training: Oil explosion, aerosol explosion, fryer fire bin fire, screen fire, electric motor fire, or electrical cabinet fire.

This manual has been designed to allow safe use of **PYROS 3**. Instructions for use and maintenance must be followed to prevent incidents.

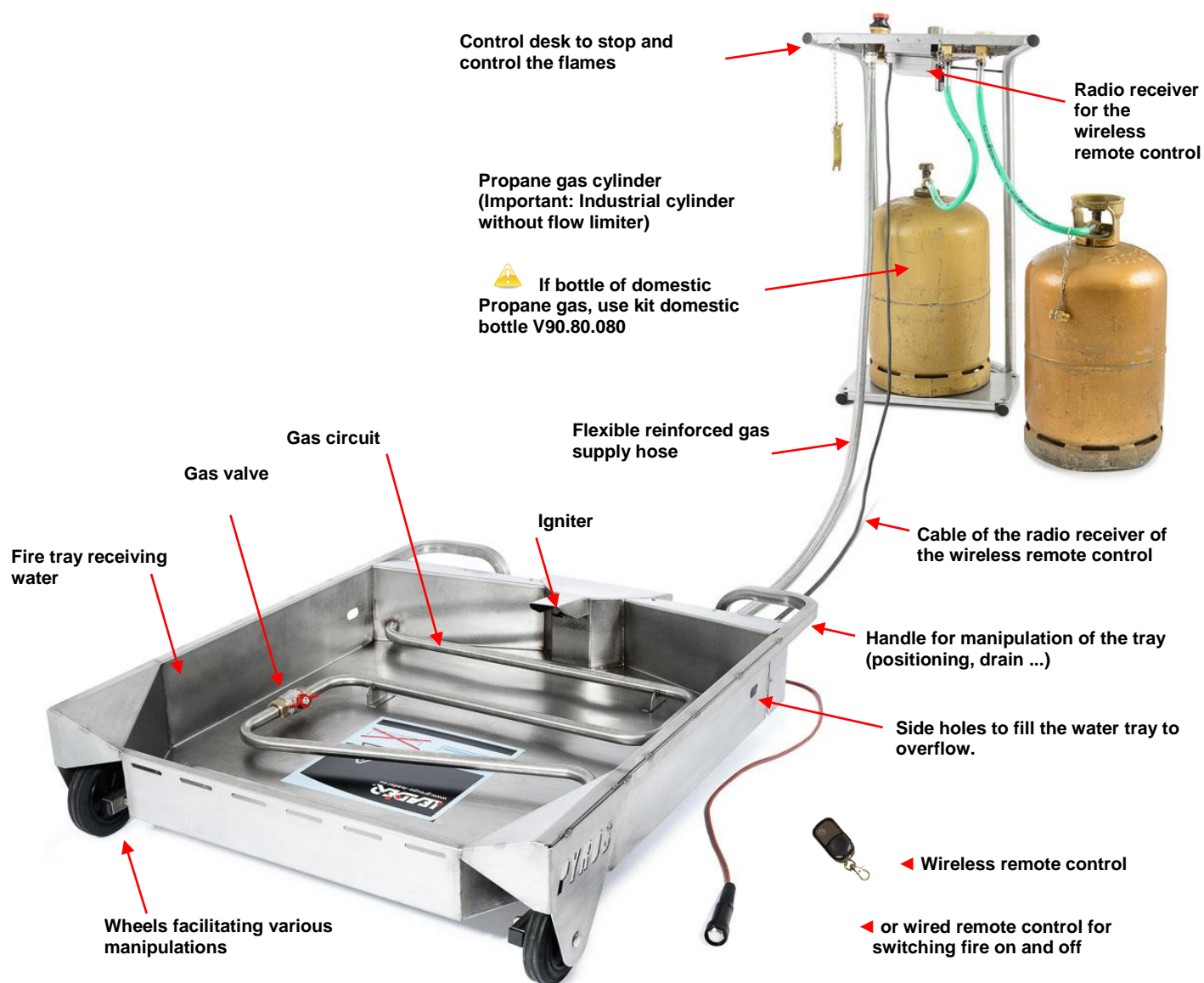

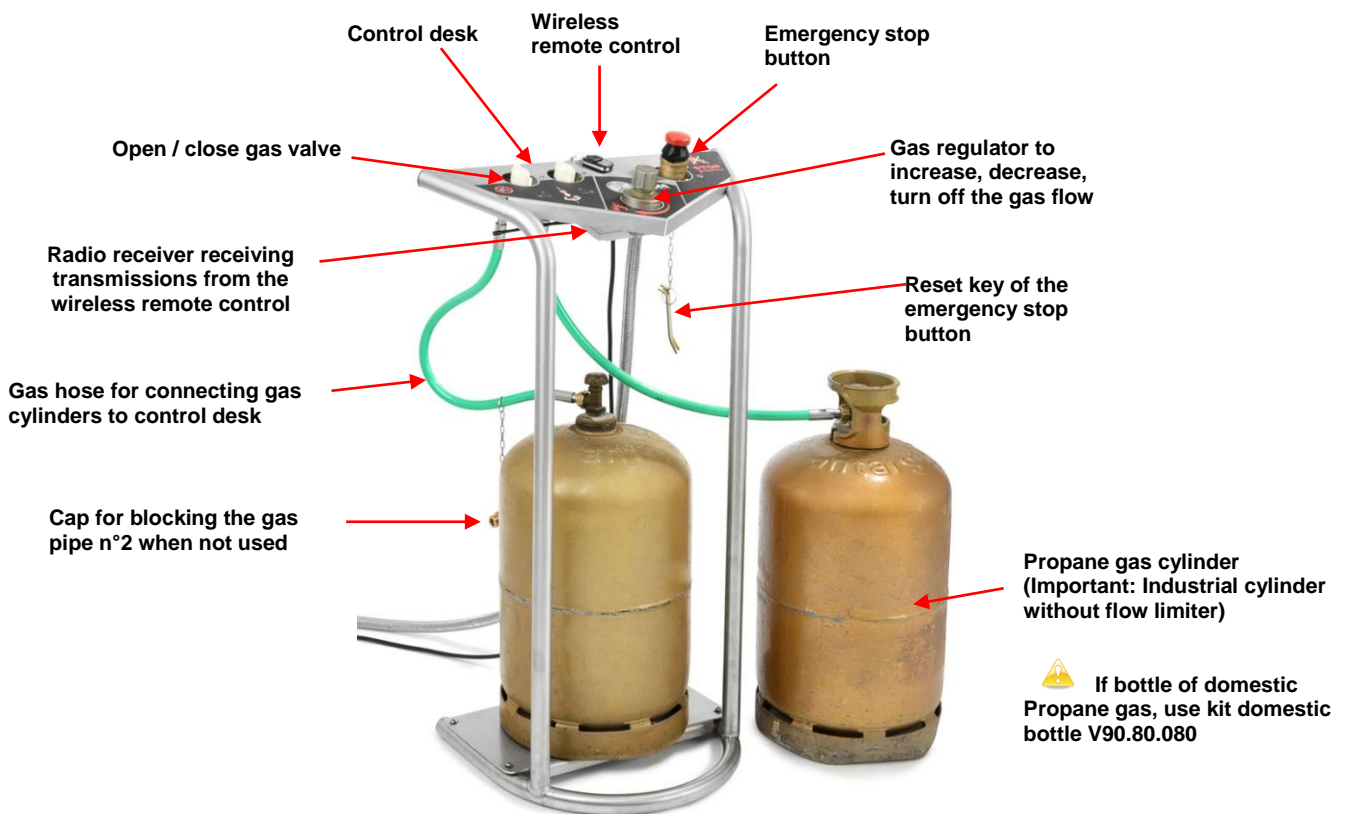
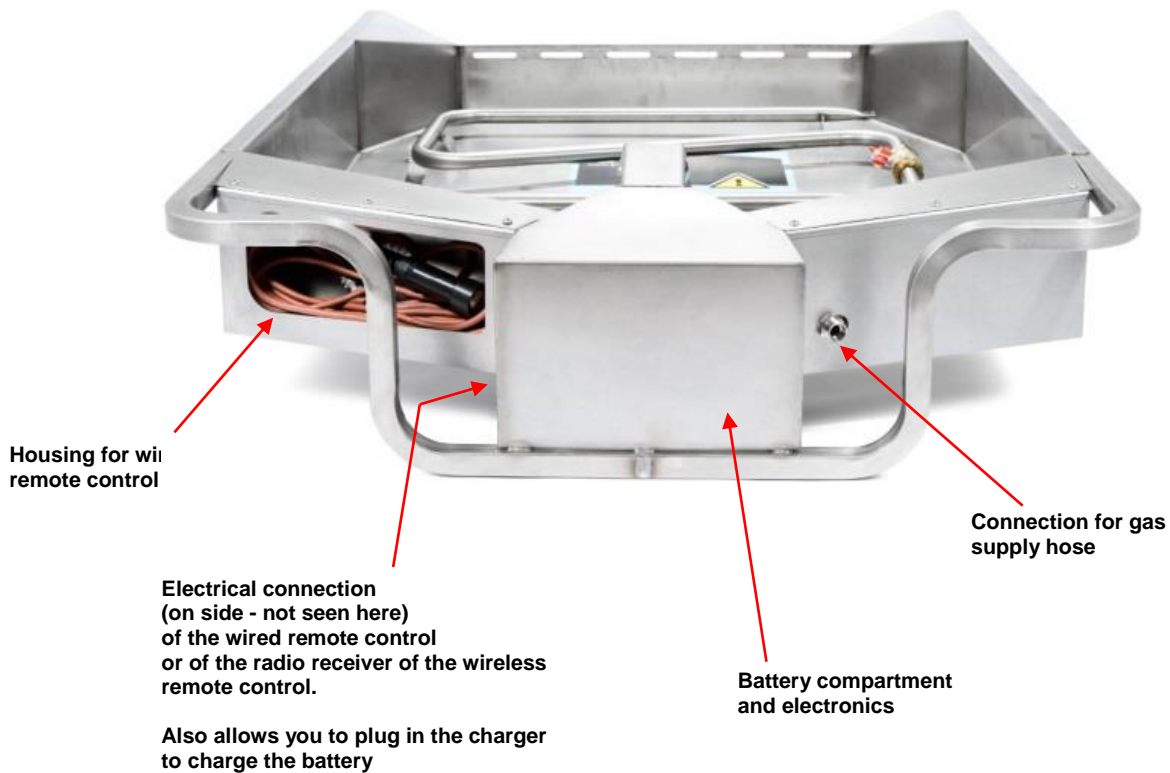

## 2 SAFETY INSTRUCTIONS



**- ATTENTION - ATTENTION - ATTENTION - ATTENTION - ATTENTION -**



- Read this manual completely and the instructions before implementation and use of the equipment.
- Never use **PYROS 3** tray without water.
- Regularly check the reinforced gas supply hose.
- The device only works with Propane gas.
- Use **PYROS 3** only outdoors and away from flammable items.
- Respect the safety distance tray / gas cylinder. It is given by the length of the 6 m gas supply hose.
- Never use **PYROS 3** beyond a pressure of **3 bar**.
- Wear gloves for use and handling **PYROS 3** elements to avoid any incident. (cutting, burning ...)
- The trainer must permanently keep in hand the remote to control the fire.
- Never keep down the remote control button if no flame. This will remove the risk of spread of non-ignited gas and its sudden inflammation outside fire tray.
- Any operation or attempt to disassemble, excluding consumable items such as the battery or fuse, will void the manufacturer warranty.
- **PYROS 3** operates only with gas in gaseous phase.  
It is forbidden to feed your flame generator with propane in liquid form, especially with carburetion bottles.  
For good supply of the tray, the gas cylinders must be positioned upright. Never lie on the side the gas cylinders. The **PYROS 3** would work with gas in liquid phase and would be irreparably damaged.
- Take care not to introduce sand or gravel in the gas supply hose or fittings of the unit. This could damage the internal valve.
- The battery can be discharged to a minimum limit of 10 volts. Below this voltage, it will not charge correctly anymore.
- Always replace defective parts with original parts supplied by **LEADER**.
- Keep the unit away from children.
- Do not use **PYROS 3** in windy weather.
- Activate the emergency stop button before handling the tray (installation or removal of such accessories)
- Do not smoke while handling the **PYROS 3**

### **REMINDER:**

- Do not store propane gas cylinders inside a room. Provide an external storage.
- Training equipment using explosive fuels are intended for use by experienced professionals. **LEADER** declines all responsibility for accidents or damage involving people or property.





### 3 GENERAL CHARACTERISTICS & PERFORMANCES

#### 3.1 General characteristics

❖ **Manufacturer: LEADER S.A.S**  
**ZI des hautes vallées**  
**Chemin N°34**  
**76930 Octeville sur Mer**  
**FRANCE**  
[www.leader-group.eu](http://www.leader-group.eu)  
[www.LeaderNorthAmerica.com](http://www.LeaderNorthAmerica.com)

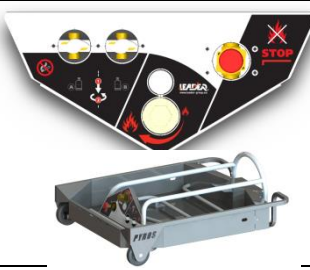
**Distributor :**  
 --to be filled in by the distributor--

▪ **Content and features :**

	<b>PYROS water fire pan</b>
	Material: Stainless steel 304
	Dimensions: L117 x W96.5 x H26 cm – L3.84' x W3.17' x H0.85'
	Weight: 41,8 kg – 92.15 lbs.
	Fire area: 0,83 m <sup>2</sup>
	Water capacity: 62 liters – 13.64 gal Gas flow rate at 1 bar = 36 kg/h – 79.37 lbs/h , nominal flow rate at 2 bar = 59 kg/h – 130.07 lbs/h. Built-in rechargeable battery: 12 volts. Water and dust resistant (IP67) connectors equipped with protective caps.
	<b>Gas supply control panel</b>
	Material: Stainless steel 304
	Dimensions : L57 x W39.5 x H99 cm – L1.87' x W1.3' x H3.25'
	Weight: 8,8 kg – 19.4 lbs.
	Gas pressure adjustable from 0 to 3 bar by pressure controller equipped with pressure gauge "Emergency punch stop button" safety system. Water and dust resistant (IP67) connectors equipped with protective caps.
	Gas supplied by 1 or 2 propane cylinders (industrial type) without flow limiter (not provided). Console easy to carry: stored in the fire container.
	<b>Wired remote control</b>
	Fire ignition and extinction remote control with safety switch. Resistant to water splashes.
	Electric cable: length 9 m (29.6') – fire resistant (Standard CEI 331)
	<b>Wireless remote control</b>
	Range of 30 meters – 98.5' Resistant to water splashes.
	<b>Flexible reinforced gas supply hose</b>
	Length: 6 m (19.7') with screwed coupling
	Self-sealing.
<b>Packaging</b>	
Carton case on a 120x100 cm palette	
<b>Temperature of use</b>	
from -5°C to +40°C	

## 3.2 Charger characteristics

**Supply:** 110 / 220 V – 50 Hz Frequency

**Charge time:** 24 hours (when battery is fully discharged). Rely on the light on the charger.  
For more information see the manufacturer attached manual of the charger.

## 3.3 Gas supply

Possible with one or two industrial Propane gas cylinders of 13 kg type without flow limiter or fourth cylinders 13 kg Propane domestic type with two kits flow limiter **réf: V90.80.053**

Adjustable flow regulator gas.

Gas supply hose of 6m to be screwed.

It is advisable to use industrial or domestic Propane gas cylinders (13 kg or 35 kg) from Antargaz company (France). For supply points: [www.Antargaz.com](http://www.Antargaz.com)  
Outside France, consult the country's gas supplier.

## 3.4 The remotes control

**PYROS 3** comes with one wired remote control and one wireless remote control.

A single remote control can be used at once as only one electrical connector is placed on the tray.

## 3.5 Wired remote control

-It Connects directly to the tray, allowing the ignition and extinguishing of the fire.

-Water resistant.

-Designed to avoid accidental triggering. The control button is indeed protected by a cover which overlooks the button height. To trigger the burning gas, the button must be deliberately push. In the event of a fall or shock it protects it.

-Electrical cable length: 9 meters

-Fire resistance: Certified to IEC 331.

-Temperature range: -60 ° C to 180 ° C.



## 3.6 Wireless remote control

-Range: 30 m

-Battery: GP27A 12V 18mAh

-It Works hand in hand with a radio receiver attached under the table desk. This module consists of a housing with its antenna and is resistant to water.

-The electric cable which connects the receiver to the tray is the same length as the reinforced gas supply hose.

-Temperature range: -60 ° C to 180 ° C.





## 4 IMPLEMENTATION INSTRUCTIONS



Use within a room can cause gas buildup and explosion!  
**DO NOT USE INDOOR PYROS 3.**

**Before use:** Charge the battery at least 12 hours.

### 4.1 Assembly of the gas cylinder holder assembly

Assemble the holder on the desk with the Allen wrench 4 screws and 4 M6 washers.

This room is designed to accommodate a Propane gas cylinder and allows stability of the desk during the use. A second gas cylinder can be added next to the control desk.

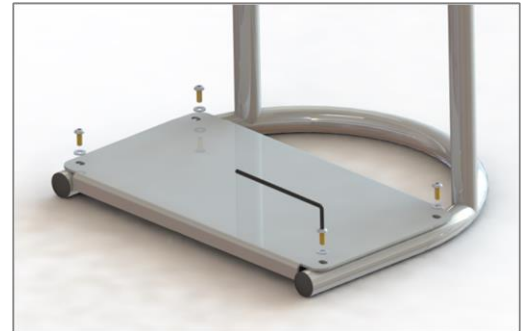

### 4.2 Connections and implementation

#### a. Drawing of connections for use of the wireless remote control

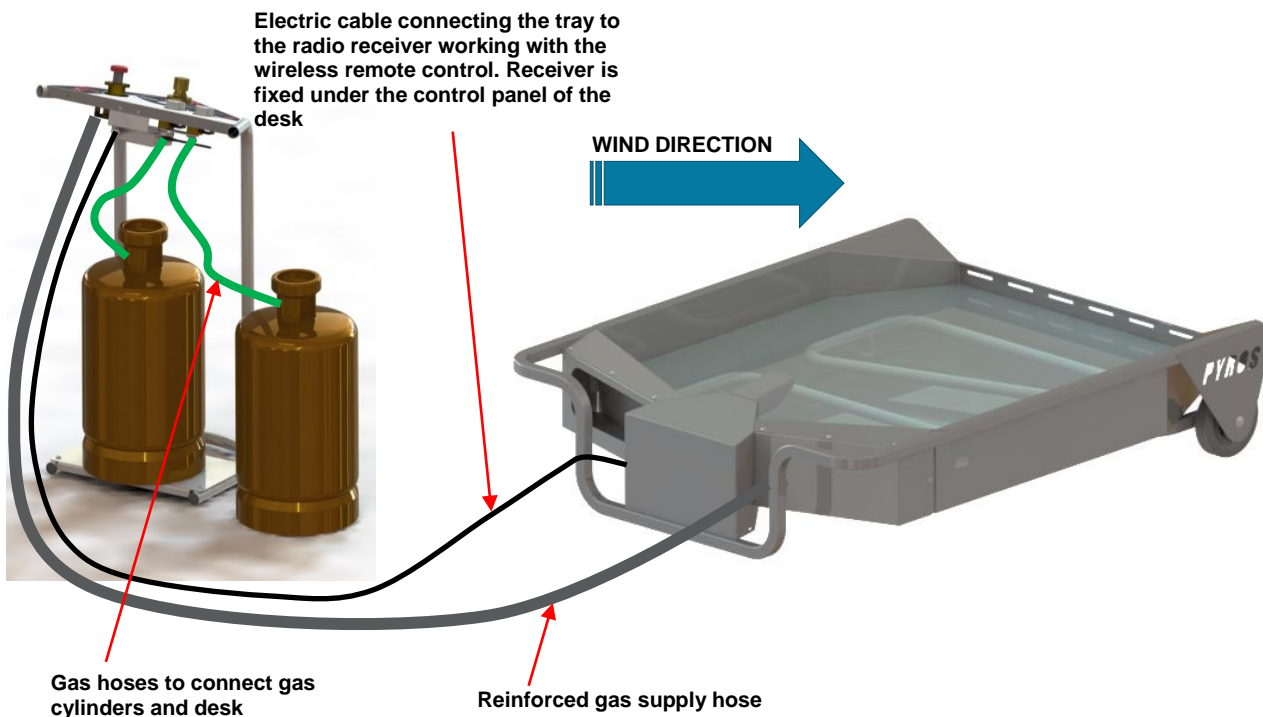

## b. Drawing of connections for use of the wired remote control

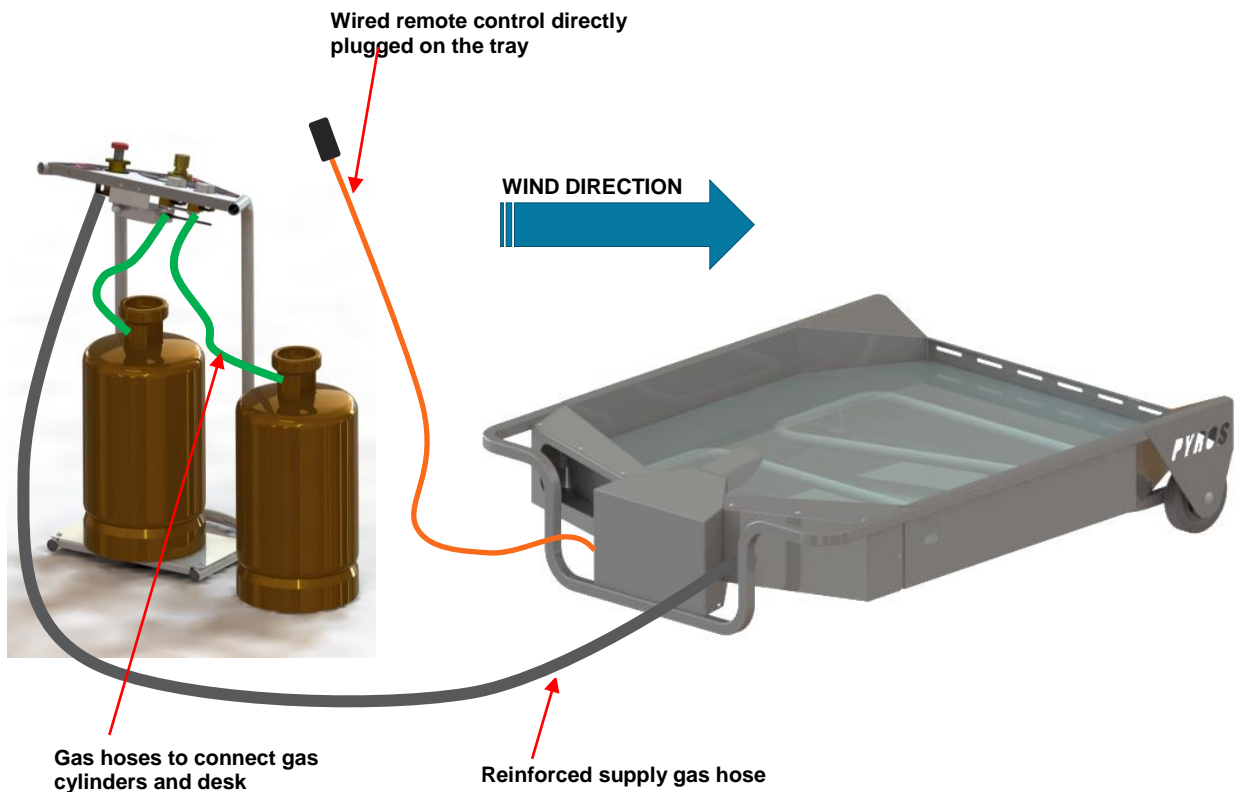

### 4.3 Gas cylinder connection

Hand tighten the gas connection pipe valve on the gas cylinder.

### 4.4 Positioning of the tray to the ground

Positioning the fire tray on a flat surface, so that the water level is equal everywhere. Place it so that the cable of the remote control and the gas supply hose are opposite to the wind direction.

Do not fill the water tray at this stage.

### 4.5 Gas supply hose connection

Hand tighten the gas supply hose connection. Perform the same operation on the desk with the other end of the gas supply hose. Connect the tray to the control desk without creating elbow during the implementation of the gas supply hose.

## 4.6 Remote control connection

After removing the protective cap of the connector, connect the remote control cable of the wired remote control or the wireless remote control (cable of the radio receiver). The connection must be done before any water filling operation of the tray to avoid wetting the electrical connector.



Drawing showing the connection of the wired remote control.

Operate in the same way with the cable of the receiver working with the wireless remote control.

The radio receiver is fixed under the control panel of the desk.

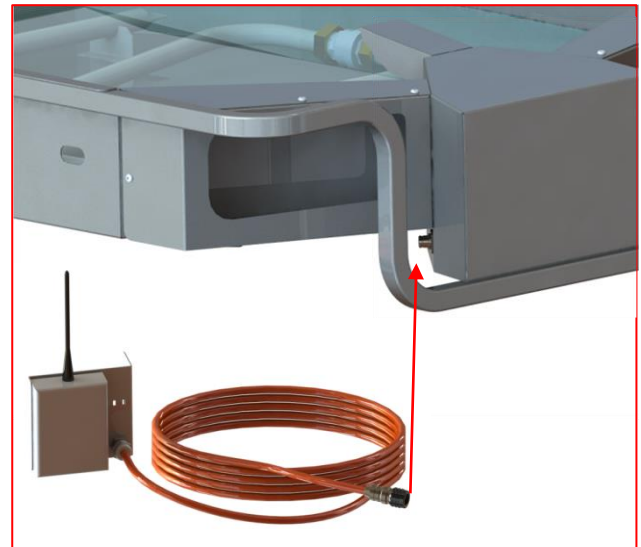

## 4.7 Filling the tray

Fill the tray with water to overflow through the side holes.

In use, the water evaporates due to the heat generated by the fire. These openings are a good marker of the level of water. Make up the water when necessary.

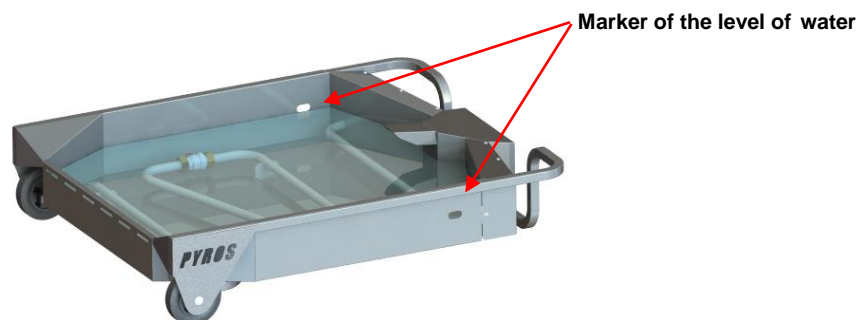

## 5 USE OF PYROS 3

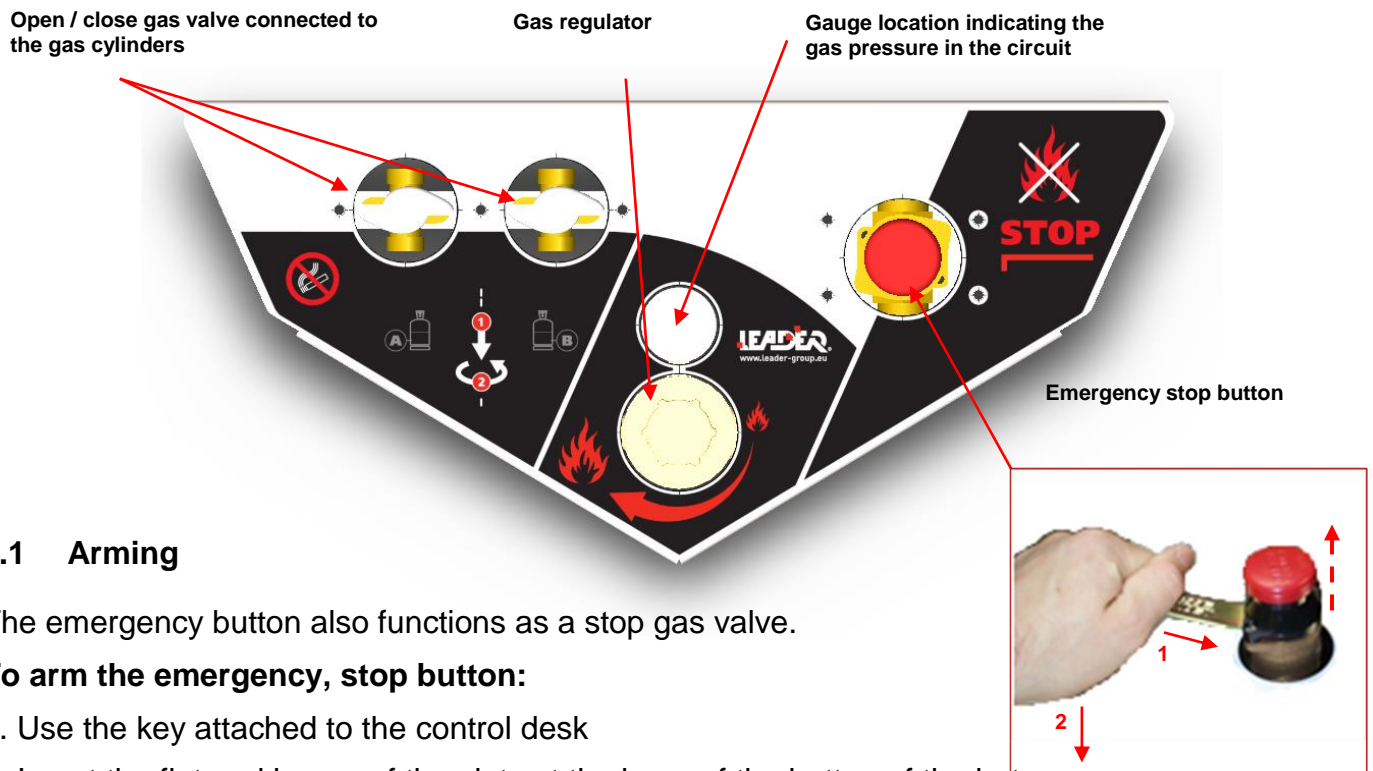

### 5.1 Arming

The emergency button also functions as a stop gas valve.

#### To arm the emergency, stop button:

1. Use the key attached to the control desk
2. Insert the flat end in one of the slots at the base of the button of the hat
3. Lever as shown against until it clicks

#### Use:

1. Open the corresponding valves to the cylinders used (one or two).

2. Arm the system via the emergency stop button. The fire tray is then supplied with gas, ready to work.

3. Keep the remote control in hand.

4. Adjust the gas outlet pressure using the gas regulator.

**For ignition, the pressure should be less than or equal to 1 bar. The pressure gauge allows visualizing the pressure.**

5. Press the remote control button to ignite the fire tray.

6. Using the gas regulator, adjust the gas flow to adjust the flame height (0.20 to about 3 meters). Turn in the direction of clockwise to increase the flame height. Gas outlet pressure is displayed on the gauge.

**The pressure must not exceed 3 bar use.**

7. Release the button to turn off the fire.



## IMPORTANT:

Always keep your eyes on the fire tray and the people around it, when you manoeuvre the remote control.

Always keep the remote control in hand and stay close to the control desk ready to activate the "emergency stop button" in case of problem.

If the trainer is away from the control desk, a person must be designated to stay close to the desk, ready to pull the "emergency stop button" in case of problem.

## 5.2 Use of extinguishing agents

You can work on **PYROS 3** with any extinguishing agent.



Beware of the use of foam concentrates: it traps the gas, which could ignite further outside of the tray.

When the trainee has extinguished the fire, release the button on the remote.

When using a fire extinguisher or  $\text{Co}_2$ , it is possible that a trainee "blows" the flames. Then release the button on the remote. The trainee will have the impression of having extinguished the fire.



**To avoid the risk of spread of non-ignited gas and its sudden inflammation outside the tray, never hold down the button on the remote if no flame.**

## 5.3 Instructions for use

Wait a few seconds before relighting the fire after an intervention so that the ignition system is no longer saturated with gas.

Never use **PYROS 3** without water.

Think regularly to top up the level of water during training courses.

## 5.4 Stop PYROS 3

1. Close gas cylinder valves
2. Press the button on the remote control. This activates the solenoid and allows to empty the gas in the system.  
Please note that this action may ignite the waste gases.
3. Press the emergency stop button on the control desk.
4. Put the gas valve on position 0 (unscrew maximum).
5. Close the opening / closing valve gas on the desk
6. Disconnect the gas supply hose and the remote control. Do not forget to put the protective cap on the electrical connector on the tray.
7. Flip the tray to drain its water. Tilt the tray with the wheels on the ground on the opposite side of the igniter to avoid wetting the compartment containing the battery and electronics.

Do not drain the water at this side of the tray. There is the battery / electronics compartment.

Tilt the tray with the handles

Drain at the wheels side

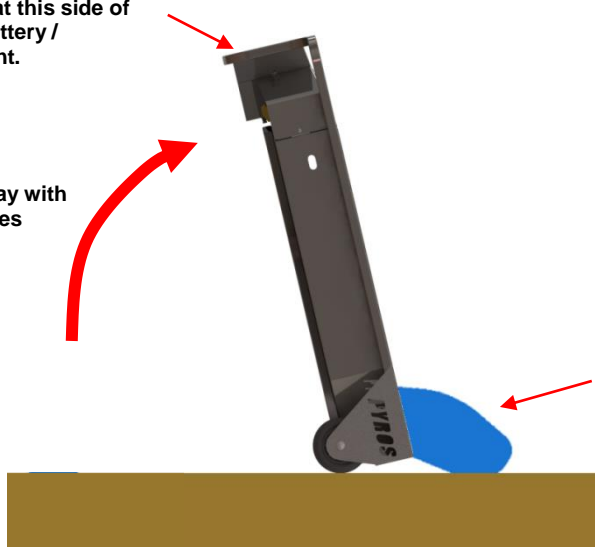

## 6 AUTONOMY AND POWER

For information, the autonomy of **PYROS 3** is about 58 min using industrial gas cylinder without flow limiter.











However, the power and autonomy of **PYROS 3** depend on the gas cylinders flow.

The flow of a gas cylinder varies according to two factors:

1. Ambient temperature: The higher it is, the more the rate will be important.
2. The duration of use: The longer it is, the more the possible flow will have to be low.

### Number of achievable burns with 2 Propane gas cylinder 13 kg:

This table is estimated. The values are approximate and for an ambient temperature of 15°C.

Time of each fire (in seconds)				
	10''	15''	20''	30''
Pressure (bar)				
0.50 	930	620	460	310
1.00 	465	310	230	150
1.50 	310	200	155	100
2.00 	230	150	115	80
2.50 	180	125	95	60
3.00 	150	100	80	50

## 7 SERVICING OPERATIONS

### 7.1 Precautions



#### Beware of hot parts:

- The entire upper part of the tray is hot after use
- Before handling the tray, sprinkle it with water to cool it
- Wear gloves

### 7.2 Cleaning

- Before washing operation: Disconnect the remote control cable and position the protective cap on the connector.
- In the case of using water nozzle or training water extinguisher: Rinse the tray with water to get rid of the various residues.
- In the case of using Co2 extinguisher or foam concentrate: Dry clean with a tissue so as to remove powder residue or other extinguishing agents (thoroughly stress at the igniter). Then wash the tray with water.
- In the two previous cases, and to remove soot, clean the tray with an Inox special detergent "Pyroclean" type; Apply with a damp sponge, then rinse with water and dry with a soft tissue.
- Dry the sensitive parts such as the electrical connector and fittings of the tank and gas supply hose. Also check the holes so they do not have sand or gravel. They would damage the valve.

### 7.3 Charging the battery

Plug the charger into the connector of the tray which is also used to connect the cable of one of the remotes control.

Then connect the charger to the mains.

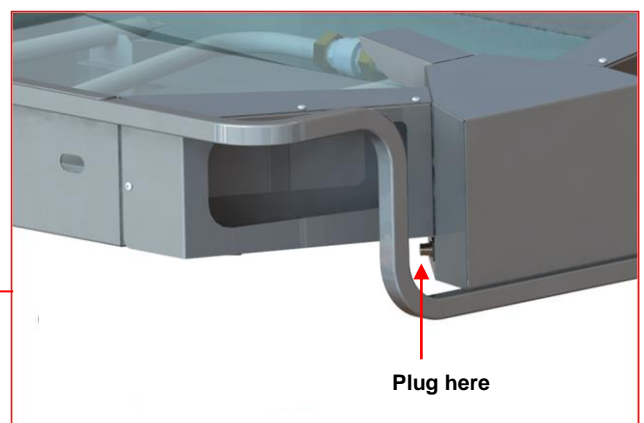
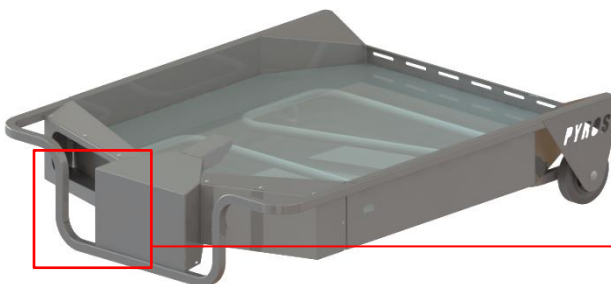





**Note:**

The charging time of an empty battery or the first charge is about 24 hours. Also consult the manufacturer's instructions. It is recommended to recharge the battery after each use or 1 time per month when not in use.

## 8 ACCESSORIES USE (OPTIONS) :

The trainings conducted with **PYROS 3** can be supplemented with the use of training modules and enable personalized and realistic training: Oil explosion, aerosol explosion, fryer fire bin fire, screen fire, electric motor fire or electrical cabinet fire.

### 8.1 Adapter and accessories

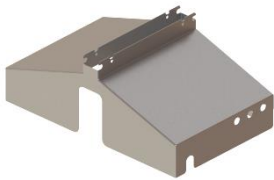

**Unique adapter with fixing shapes**

Ref : V90.80.077



**Bin**  
To be fixed on flat screen (ref. V90.80.071)

H : 14 cm  
W : 39.5 cm  
D : 26 cm  
Weight : 1.4 kg

Ref : V90.80.070



**Flat screen**

H : 38 cm  
W : 46.5 cm  
D : 8.5 cm (base 14.5 cm)  
Weight : 4.6 kg

Ref : V90.80.071



**Fryer fire module**  
To be fixed on screen (ref. V90.80.071) and bin (ref. V90.80.062) set

H : 14 cm  
W : 39.5 cm  
D : 26 cm  
Weight : 1.4 kg

Ref : V90.80.070



**Electrical cabinet:**  
1 door removable key that is fixed on 1 screen (ref. V90.80.071)

H : 38 cm  
W : 46.5 cm  
D : 11 cm (base 14.5 cm)  
Weight : 6.5 kg

Ref : V90.80.075



**Electric motor**

H : 35.5 cm  
W : 32.5 cm  
D : 56 cm  
Weight : 6.8 kg

Ref : V90.80.063



**Aerosol can explosion module**

To be used only with LEADER aerosol cans  
H : 2.5 cm  
W : 26 cm  
D : 20 cm  
Weight : 6.9 kg

Ref : V90.80.072



**Oil explosion module**  
To be fixed on adapter (Ref : V90.80.077)

To be used with vegetal oil  
H : 45 cm  
W : 26 cm  
D : 30 cm  
Weight : 2.8 kg

Ref : V90.80.073



Read carefully the specific instructions of this aerosol explosion module before use.



**Domestic Bottle Kit**  
For domestic bottle (V90.80.080)

## 8.2 Implementation of the adapter and accessories

The trainings must be completed with accessories on tray filled with water only.

### Prior to manipulating the tray, shut down the system:

1. Turn off the gas supply by pressing the emergency stop button
2. Purge the line by pressing the remote control button and let the remote on the control desk
3. Close the valve located at the bottom of the tray on the gas circuit to concentrate the action of flame only in the adapter

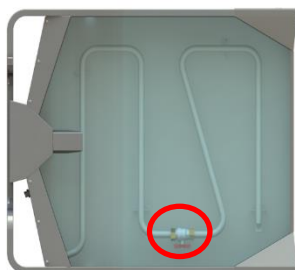

4. An adapter (support for various training accessories) should be positioned in the tray. It also concentrates the flames. The adapter must be positioned on the first side of the tray (side without wheels). The notches in the base of the adapter must fit on the gas circuit. Accessories land on this adapter.

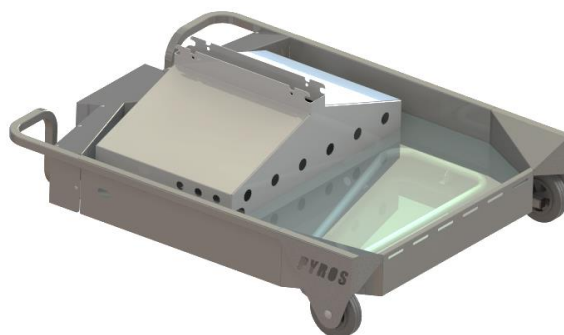
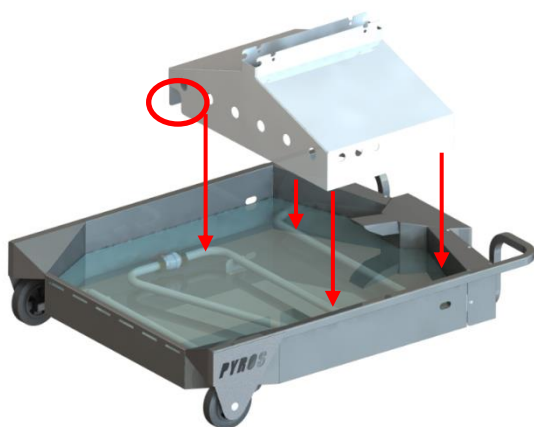

5. Adjust the gas regulator at a low rate (1 bar max).
6. When you release the button on the remote control, the fire can continue for a while in the accessory, because it was filled with gas. Wait several seconds before re-ignite so that the adapter and the accessory are no longer saturated with gas.



**Nota:** The accessories allow to obtain different shapes/height of flames. By leaving open the valve, we can simulate the burning of the accessory and the full tray.

### 8.3 Handling Training accessories

Wear gloves when handling the adapter and the various accessories during training. These are very hot because of the fire generated by **PYROS 3**. Before removing an accessory, think to cool it with some water.

## 9 FAILURES

Symptom	Possible origin	Solutions
The flame height is not large enough	Is the gas cylinder full enough?	Replace the gas cylinder
	Is the regulator flow adjustment knob sufficiently screwed?	Screw the gas regulator
	The gas cylinder is frozen (the use was too intense)	Change the gas cylinder or wait until it defrosts.
	Are the climatic conditions favourable?	A very low outside temperature significantly affects the importance of the fire. The fire will be more effective during summer than winter.
Nothing happens when you press on the remote control	Is the battery charged?	Connect the charger to <b>PYROS</b> tray and plug it to the mains.
	Is a remote control connected?	Connect the remote control.
	Is the electrical connector on the tray dry?	Disconnect the remote control cable and dry its plug and connector on the tray.
	Are the batteries in the wireless remote control (if used) full?	Change the cell batteries.
	Is the fuse still operational?	Change the fuse.
The gas does not come out (no "bubbles" in the water). However, the spark occurs (we hear the continuous "tac tac" of the igniter)	Is the gas cylinder open?	Open the gas cylinder.
	Check the position of the gas regulator.	Open the gas regulator to 1 bar.
	Do you hear the "tac" of the solenoid when pressing the remote button?	If not, the solenoid valve may be defective. The repair must be done at the factory.
The gas exits ("bubbles" in the water) but does not ignite	The igniter is saturated of gas	Wait a few moments to have sufficient ventilation.
	A drop of water can be hooked to the electrodes.	Kick on the tray to drop a potential water drop.
	De la poudre d'extincteur a-t-elle été utilisée lors des exercices ? Does some extinguisher powder have been used during the training course?	The electrodes are dirty. Wash with water and dry them with compressed air.
	Do you hear the "tac tac" of the igniter?	If not, the white high voltage block of the igniter may have blown. Its change must be made at the factory.

## 10 WARRANTY



### LEADER WARRANTY

**LEADER** equipment has a contractual limited guarantee from the date of purchase, defined below by product, parts and labor (excluding transport costs and travel).

This warranty is specifically limited to replacing or repairing the equipment (or its parts) which proves defective after examination for reasons attributable to **LEADER**.

To initiate this warranty, with the agreement of **LEADER** the claimant must return the equipment in the shortest possible time after discovery of the defect to the following address:

**LEADER SAS**,  
Maintenance Department,  
ZI des Hautes Vallées Chemin No. 34, CS 20014,  
76930 Octeville Sur Mer,  
France,

### OUT OF WARRANTY EQUIPMENT

A complete analysis will be carried on your faulty equipment, after which a detailed quote will be offered.

For faults and non-warranty repairs, a diagnosis fee will be applied independently of the acceptance of the repair estimate.

Our after sales service is committed to a processing time, upon acceptance of the quote.

### LEADER AFTER SALES SERVICE

After Sales Service is composed of areas of expertise organized by product departments. The benefits of our service are numerous:

- Support on and off in our warranty repair
- Referenced parts (exploded view and parts list)
- Loan of equipment (identical or similar) during troubleshooting
- Expertise and assistance remote troubleshooting
- Expert technicians at your disposal to share our expertise and knowledge





# LEADER

---

## MANUFACTURER

---

### **LEADER S.A.S.**

Z.I. des Hautes-Vallées  
Chemin n° 34  
CS20014  
76930 Octeville sur Mer  
France



[www.leader-group.eu](http://www.leader-group.eu)

---

[www.LeaderNorthAmerica.com](http://www.LeaderNorthAmerica.com)

Our policy is to constantly seek to improve our products. We therefore reserve the right to change their technical specifications at any time and without prior notice. - Non contractual images



PLEASE RECYCLE

Code Notice :  
PYROS 3.00.ZN.4.65.EN.4